



ULD CONTAINERS SPECIFICATION IN AIR TRANSPORT

ULD = UNIT LOAD DEVICES

Special aircraft containers are primarily used in Narrow-body and Wide Body aircrafts.

For **Wide-body planes** we take care of certified cargo loading on **PMC pallets**. Dimensions and parameters of pallets, including payload (total weight) are variable according to airline options and the aircraft type.

Basic ULD container types are as follows:

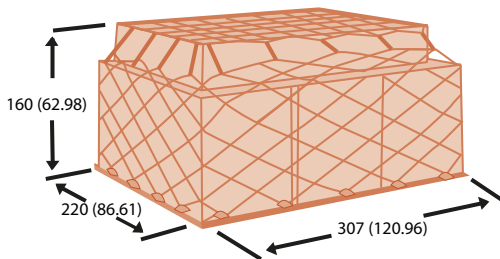

PAG/P1P

Internal volume: 11,1 m³, max. load capacity : 5926 kg

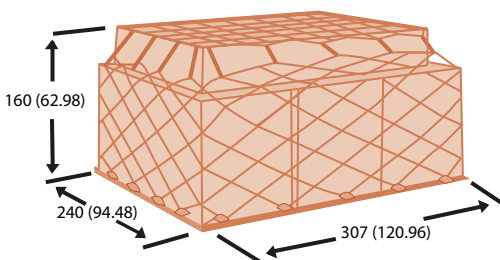

PMC/P6P

Internal volume: 12,1 m³, max. load capacity: 6663 kg

* container diameters are in cm (inch).

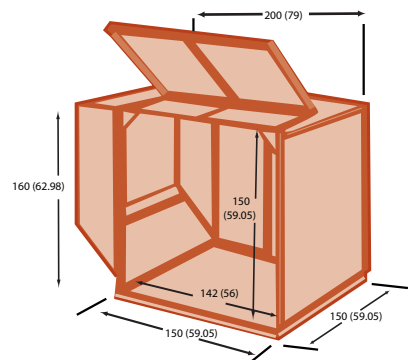

AKE/LD3

Internal volume: 4,3 m³, max. load capacity: 1501 kg

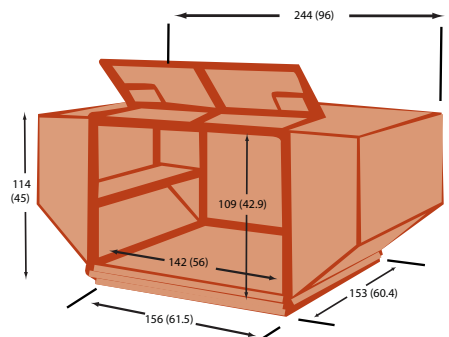

AKH/LD-3-45

Internal volume: 3,6 m³, max. load capacity: 1134 kg